

Voltage Profile Improvement and Line Losses Reduction using DG using GSA and PSO Optimization Techniques

Hardeep Singh
M. Tech. Student
Indus College Jind, India

Shelly Garg
Assistant Professor
Indus College Jind, India

Abstract

In recent years, the power industry has experienced significant changes on the power distribution systems primarily due to the implementation of smart-grid technology and the incremental implementation of distributed generation. Distributed Generation (DG) is simply defined as the decentralization of power plants by placing smaller generating units closer to the point of consumption, traditionally ten mega-watts or smaller. The distribution power system is generally designed for radial power flow, but with the introduction of DG, power flow becomes bidirectional. Therefore this thesis focuses on testing various indices and using effective techniques for the optimal placement and sizing of the DG unit by minimizing power losses and voltage deviation. A 14-bus radial distribution system has been taken as the test system. The feasibility of the work lies on the fast execution of the programs as it would be equipped with the real time operation of the distribution system and it is seen that execution of the DG placement is quite fast and feasible with the optimization techniques used in this work.

Keywords: PSO Optimization Techniques, GSA

I. INTRODUCTION

Until the 1870s electricity was a matter of concern only for engineers and researchers. Several experiments were conducted to study more about electrical phenomena, and batteries were the main source of power. The Belgian researcher Zenobe Gramme invented the generator, which could supply greater electrical currents than the battery. Electricity feeders were then build from small and large power plants to supply light and run electricity machines for primary and secondary industries. The first incandescent lamp came into being around 1880, invented simultaneously by Thomas Alva Edison and the English man Joseph Swan. Electricity had finally reached its consumers providing the demand and rational for electricity power delivery systems. Power Distribution Systems a Distribution network has typical characteristics of its own. Distribution networks design will be introduced though this article. Also the differences between country and urban distribution networks will be clearly defined. Solution techniques for DG deployment can be obtained via optimization methods in order to maximize DG benefits. Several optimization techniques have been presented by researchers in determining the optimal location and size of DG. The major objective of DG placement techniques used in the literature is to minimize power system losses. However, other objectives, like improving the voltage profile and reliability and maximizing DG capacity and cost minimization. Definition Distributed generation is a new approach in the power industry. In fact, it is so new, neither a standard definition nor a standard name for it have been agreed upon. Nevertheless, various definitions and names have been used in the literature.

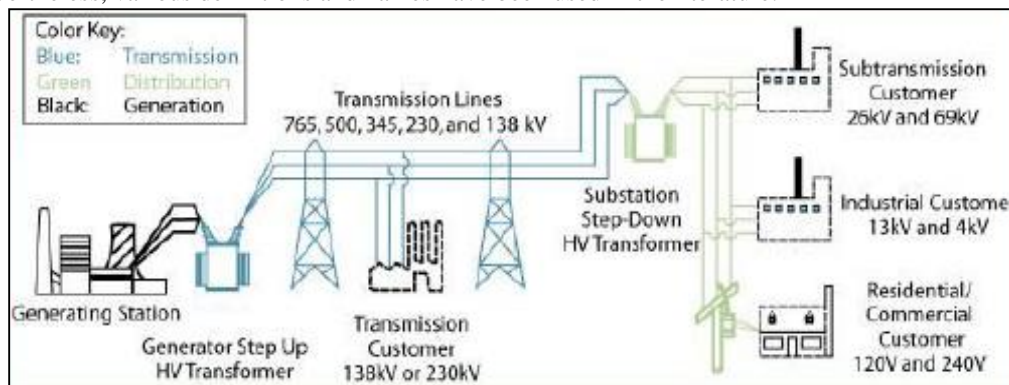

Fig. 1: Diagram of a distribution system [1]

Voltage variation and harmonic distortion are two major disturbances in distribution systems. The voltage drop occurs because of increasing electricity demand, thereby indicating the need to upgrade the distribution system infrastructure.

The main objective of this thesis to mitigate voltage variation and harmonic distortion in distribution systems, several strategies were applied, such as the use of passive and active power filters to mitigate harmonic distortion and the application of custom power controllers to mitigate voltage variation problems.. Therefore, to improve voltage profile and eliminate harmonic distortion in a distribution system with PVDG, a noninvasive method is proposed, which involves appropriate planning of PVDG units and determining optimal placement and sizing of PVDG units the power flow algorithms have been used for determination of optimal policing but in case of complex system, this method increases the complexity to unresolved level. Metaheuristic algorithms came into existence then their iteration process made the mitigation of voltage and harmonic deviation but for multi objective cases like PVDG, all don't perform well because of limitation of falling into local maxima. Considering above issues in voltage stability of PVDG, following will be key objectives of our work by which these problems will be tried to tackle: IEEE 14 bus distribution system will be considered Optimal placement of photovoltaic cell will be considered as a solution and for this hybrid particle swarm optimization (PSO) and gravitational search algorithm (GSA) will be used as an optimization algorithm. Voltage and power constraint will be considered in the fitness function of PSO GSA

II. PROPOSED WORK

To reduce the power losses in electrical distribution system, we place the DG at those buses which is suffering form highest losses. To find these we used sensitivity analysis which provides us sensitivity buses for placement of DG. But decision of size of DG is not a liner problem. It's a non-linear problem bounded by many constraints since after DG placement at some buses, whole distribution system will be disturbed. For this purpose we used optimization algorithm which is discussed later in this chapter. For every optimization algorithm, objective function is soul of it which tells it what is to be minimized and on what factors it is dependent. Next sections in this chapter will discuss the objective function and methodology of proposed work. The objective of the optimal size and location of DG problem to minimize the total power loss and voltage profile can be expressed as:

$$\text{Minimize } P_L = \sum_{i=1}^N \sum_{j=1}^N [\alpha_{i,j}(P_i P_j + Q_i Q_j)] + \beta_{i,j}(Q_i P_j - P_i Q_j) \quad (4.1)$$

Where

$$\alpha_{i,j} = \frac{r_{i,j}}{V_i V_j} \cos(\delta_i - \delta_j)$$

$$\beta_{i,j} = \frac{r_{i,j}}{V_i V_j} \sin(\delta_i - \delta_j)$$

$$z_{i,j} = r_{i,j} + jx_{i,j}$$

Where

$z_{i,j}$ is the impedance of the line between bus i and bus j;

$r_{i,j}$ is the resistance of the line between bus i and bus j;

$x_{i,j}$ is the reactance of the line between bus i and bus j is the voltage magnitude at bus i is the voltage magnitude at bus j. We have considered the IEEE 14 bus system as our test system. Table for the bus data and line data is given in appendix A.

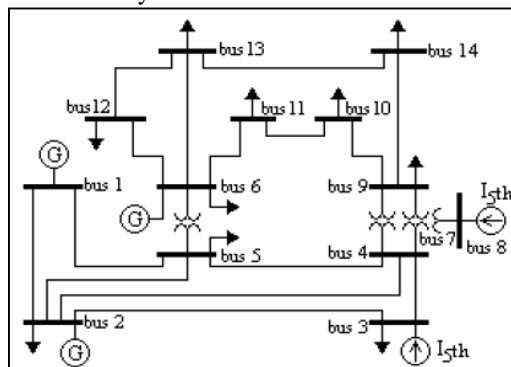

Fig. 2: bus data and line data

III. RESULTS & DISCUSSION

In our work IEEE 14 bus system as been considered as a test case to evaluate the feasibility of our proposed work. We have used Newton rahpson ac load flow analysis to check out the power losses and voltage profile in each bus. We have developed our code in MATLAB modules and are named as per their functions.

The optimization targets to minimize the objective function. If with the number of iterations, cost value or objective function value id decreasing and almost fixed at a minimum value, then optimization results can be considered as good results. We have compared our outputs with individual GSA and PSO algorithms too. The output of objective function for each PVDG value for each iteration is plotted in figure below.

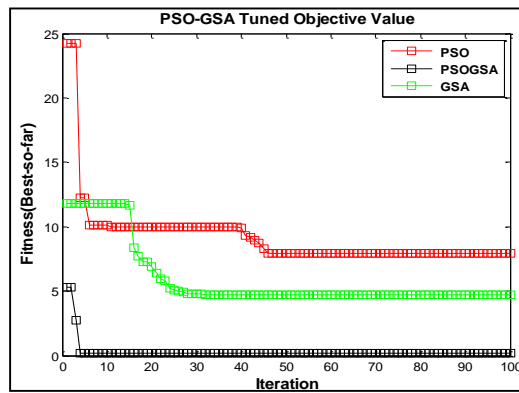

Fig. 3: Fitness function output of DG for the proposed case

In this fitness function value decreases with iterations and fixed to a minimum constant value after 3 iterations for our case. Initially the distribution generator size is taken randomly within limits Of 1-50 MW for all four potential buses. We have put the results in file after executing the script 5-6 times and best results are picked up.

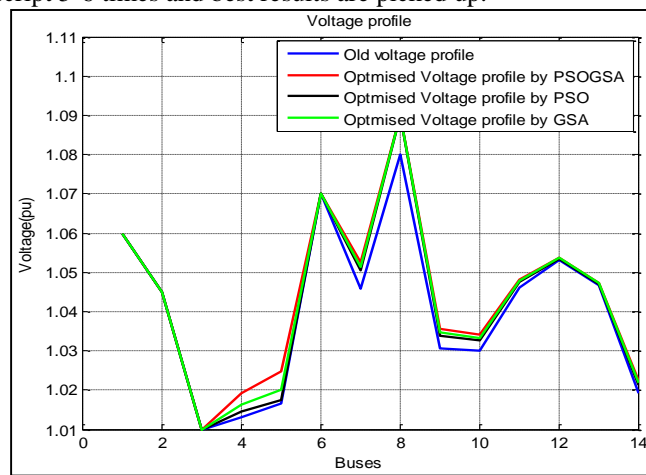

Fig. 4: Voltage profile for optimized case

Optimal sizing calculation and placement in the IEEE 14 bus system, voltage profile almost at each bus is increased. It improves because after installation, line losses in the whole system reduce.

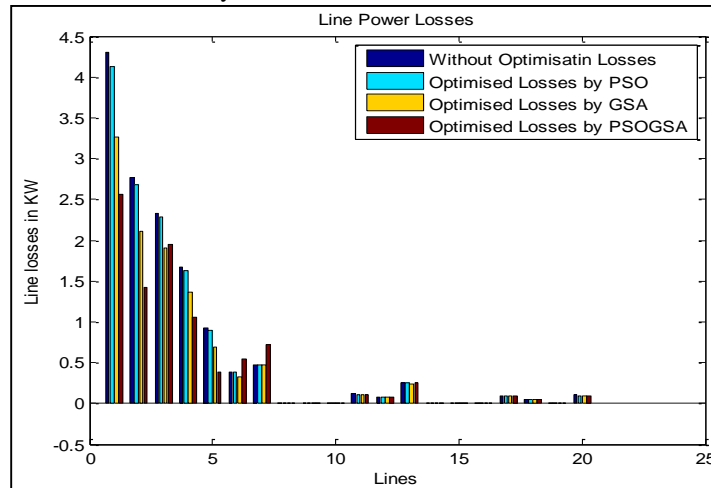

Fig. 5: Losses in between buses for optimized and without optimized case

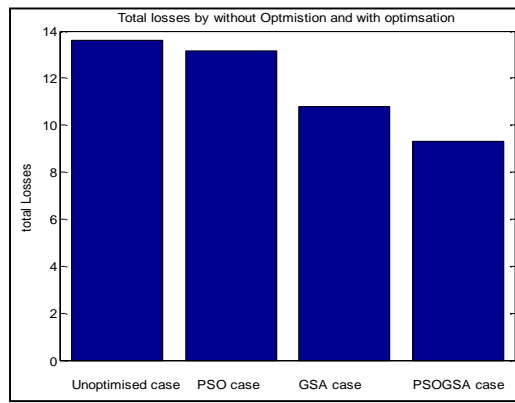

Fig. 6: Total losses for optimized and unoptimized case in the system

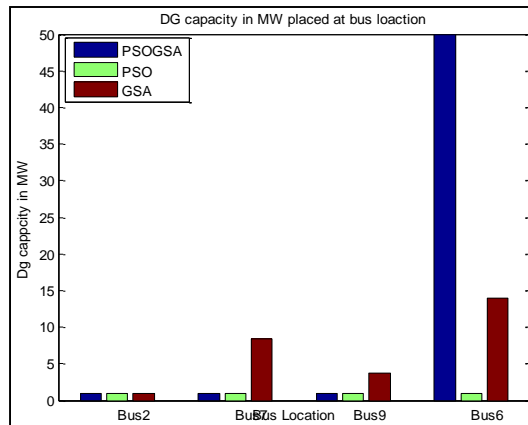

Fig. 7: PVDG capacity placed at 4 higher losses buses

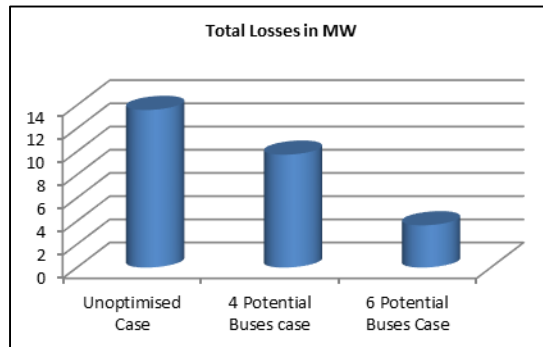

Fig. 8: Comparison of total losses in 4 potential bus case and 6 potential bus case.

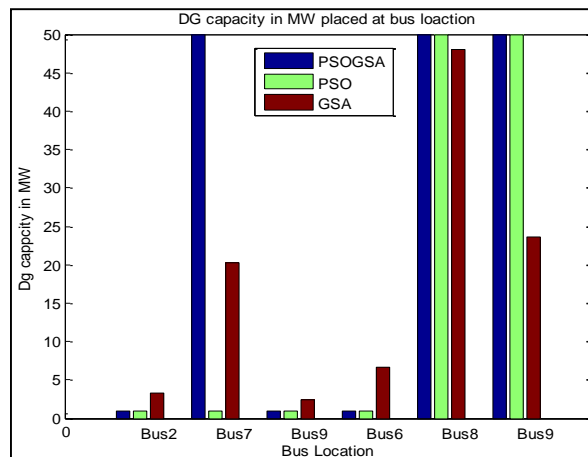

Fig. 9: PVDG capacity placed at 6 higher losses bus

For the case of 6 potential buses selection, process is same but total losses are improved although voltage profile improvement doesn't show significant improvement. Total losses after installation at 6 buses are 3.6411 MW. A comparison bar graph for all of above cases is shown in above figure. Bus number and capacity of generator placed in the system is shown in figure. If more potential buses are selected then, cost will increase which is not considered in our present case.

IV. CONCLUSION

From the results and discussions in the previous chapter it can be easily concluded that Better loss reduction was obtained in loss sensitivity method. In loss sensitivity method, 6 buses were chosen for DG placement. Since it was a junction of several branches, voltage profile improvement was better in this case In VSI method though loss reduction was less, but assessment of DG sizing was better. Since VSI method generally gives minimum sensitivity values at last buses, hence it is a very rigid and improper method for loss reduction and voltage profile improvement. Hybrid optimization PSO-GSA optimally decides the size of PVDG so that losses can be reduced significantly. The scope of future work after simulating this system is identified as Different FACTS devices such as UPFC, SVC, SSC can be simulated for the given system. The problem could be extended with complex system having multiple machines connected. Application of DG can also be applied to a deregulated system facing congestion on a distributed network.

REFERENCES

- [1] Marko Vukobratovic, "Optimal Distributed Generation Placement in Distribution Network" ENERGYCON 2014 • May 13-16, 2014.
- [2] L.M. Lukianenko, "Determination of the Optimal Placement and Capacity of Distributed Generation" IEEE International Conference on Intelligent Energy and Power Systems, 2014.
- [3] Ebrahim Babaei, "Optimal Placement of DG Units Considering Power Losses Minimization and Voltage Stability Enhancement in Power System" International Journal of Automation and Control Engineering Volume 3 Issue 1, February 2014.
- [4] S.P.Rajaram, "Optimal Placement of Distributed Generation for Voltage Stability Improvement and Loss Reduction in Distribution Network" International Journal of Innovative Research in Science, Engineering and Technology, Volume 3, Special Issue 3, March 2014.
- [5] Deepak Pandey, "Optimal Placement & Sizing Of Distributed Generation (DG) to Minimize Active Power Loss Using Particle Swarm Optimization" INTERNATIONAL JOURNAL OF SCIENTIFIC & TECHNOLOGY RESEARCH VOLUME 3, ISSUE 7, JULY 2014.
- [6] Rashmi Priya, "Optimal Location and Sizing of Generator in Distributed Generation System" International Journal of Innovative Research in Electrical, Electronics, Instrumentation and Control Engineering Vol. 2, Issue 3, March 2014.
- [7] Maruthi Prasanna, "A New Simplified Approach for Optimum Allocation of a Distributed Generation Unit in the Distribution Network for Voltage Improvement and Loss Minimization" International Journal of Electrical Engineering & Technology, Volume 4, Issue 2, March, 2013.
- [8] M. Padma Lalita, "Siting & Sizing of Dg for Power Loss & Thd Reduction, Voltage Improvement Using Pso & Sensitivity Analysis" International Journal of Engineering Research and Development, Volume 9, Issue 6 ,December 2013.
- [9] Amany M. El-Zonkoly, "Optimal Placement of Multi DG Units Including Different Load Models Using PSO" Smart Grid and Renewable Energy, 2010.
- [10] Athira Jayavarma, "Optimal Placement of Solar PV in Distribution System using Particle Swarm Optimization" International Journal of Advanced Research in Electrical, Electronics and Instrumentation Engineering, Vol. 2, Special Issue 1, December 2013.
- [11] S.Ishwarya, "ICGICT Allocation of DG for IEEE 33 Bus Systems" International Journal of Innovative Research in Computer and Communication Engineering, Vol.2, Special Issue 1, March 2014.
- [12] Subin Sunny, "The Better Optimization Technique for the Placement of DG In Order To Reduce Overall Cost of Power System" International Journal of Engineering and Advanced Technology Volume-2, Issue-5, June 2013.
- [13] M.Jegadeesan, "Optimal Sizing and Placement of Distributed Generation in Radial Distribution Feeder Using Analytical Approach" International Journal of Innovative Research in Science, Engineering and Technology Volume 3, Special Issue 3, March 2014.
- [14] Azah Mohamed, "Optimal DG Placement and Sizing For Voltage Stability Improvement Using Backtracking Search Algorithm" Int'l Conference on Artificial Intelligence, Energy and Manufacturing Engineering, June 9-10, 2014.
- [15] K. S. Verma "GA based Optimal Sizing & Placement of Distributed Generation for Loss Minimization" World Academy of Science, Engineering and Technology Vol: 1 2007-11-28.
- [16] Adnan Anwar, "Loss Reduction of Power Distribution Network Using Optimum Size and Location of Distributed Generation" Power and Energy Society General Meeting, IEEE, 2012.
- [17] D.RAMA PRABHA, "Determining the Optimal Location and Sizing of Distributed Generation Unit using Plant Growth Simulation Algorithm in a Distribution Network" WSEAS TRANSACTIONS on SYSTEMS, Volume 13, 2014.
- [18] P.Sobha Rani, "OPTIMAL SIZING OF DG UNITS USING EXACT LOSS FORMULA AT OPTIMAL POWER FACTOR" International Journal of Engineering Science and Technology, Vol. 4 No.09 September 2012.
- [19] Ram Singh, "Optimal Placement of DG in Radial Distribution Network for Minimization of Losses" International Journal of Advanced Research in Electrical, Electronics and Instrumentation Engineering Vol. 1, Issue 2, August 2012.
- [20] P. Siva Prasad, "Optimal Distributed Generation Placement in Radial Distribution Systems Based on Combined Power Loss Sensitivity Approach" National Conference on Power Distribution, DSD-CPRI, Bangalore-February 6th & 7th 2014.