

# Underground Cable Fault Monitoring & Detection System using IoT & Arduino

**Dr. H. Umadevi**

*Associate Professor*

*Department of Electronics & Communication Engineering  
Dr. Ambedkar Institute of Technology, Bangalore,  
Karnataka, India*

**Niketh B.**

*BE Student*

*Department of Electronics & Communication Engineering  
Dr. Ambedkar Institute of Technology, Bangalore,  
Karnataka, India*

**Vijaydeep**

*BE Student*

*Department of Electronics & Communication Engineering  
Dr. Ambedkar Institute of Technology, Bangalore,  
Karnataka, India*

**Vikas TV**

*BE Student*

*Department of Electronics & Communication Engineering  
Dr. Ambedkar Institute of Technology, Bangalore,  
Karnataka, India*

## Abstract

With the development and advancement in technology, things changes. As technology helps us to understand its importance like in urban areas, the electricity runs underground through electrical cable instead of typical overhead lines, which occupies less space and is considered as the most effective and efficient way of transmission but the problem arises when a fault occurs in the underground cable and is also difficult to detect the exact location of the fault during the process of repairing that particular cable and the methods in existence till now follow some algorithm in order to identify the location of the fault. The aim of this project is to detect the location of fault in underground cable lines. The proposed system finds the exact location of the open circuit fault. The fault creation is made by the set of switches. The relays are controlled by the relay driver. A 16x2 LCD display connected to the microcontroller to display the information. In case of short circuit the voltage across series resistors changes accordingly, which is then fed to an ADC to develop precise digital data to a programmed Arduino micro controller kit that further displays exact fault location from base station in kilometers.

**Keywords:** Arduino Board, LCD (Liquid Crystal Display), ADC (Analog to Digital Converter), Electrical Cable, Current Sensors, Wi-Fi Modem of IoT (Internet of Things)

## I. INTRODUCTION

In the urban areas, the electrical cable runs underground instead of overhead lines. Whenever the fault occurs in underground cable it is difficult to detect the exact location of the fault for process of repairing that particular cable. The proposed system detects the exact location of the fault and by the means of Wi-Fi modem, it is serially communicated towards the server. This fault that occurs in underground cable is a big problem till now. As it is very difficult to find the exact faulty location manually, which suddenly affects the efficiency of the cable wire due to losses occurred. Till date many techniques have already been implemented in order to detect fault in cable wire but the problem arises when determining the fault in cable wire when it is under the ground and how to access or retrieve those data related to faulty location whenever it is required. In order to fill those gaps, we propose a system which detects the exact location of the fault and through the means of Wi-Fi modem its serially communicated towards server. Through previous researches many techniques came up which were useful to overcome the problem up to some extent. Fault location detection is finding exact fault position of cable when there are any unwanted accidents like short circuit, open circuit, insulation breakdown etc. Due to large damage and inference of power cable, power authorities want to have exact fault detection method to recover power lines as soon as possible. Various methods have been developed to reduce damage and inference. But most of fault detection methods have shortcomings. Some have low accuracy, some are difficult to apply because of surrounding environment and some cause unwanted damage to healthy neighboring cable and facilities.

### A. Types of Cable Faults

Cable faults can be categorized into three main types: Open conductor faults, shorted faults and high impedance faults.

#### 1) Open Conductor Fault

An open conductor fault is where the conductor of a cable is completely broken or interrupted at the location of the cable fault. It is possible to have a high resistance shunted fault (to ground) on one or more sides of the faulted conductor's location.

#### 2) Shorted Fault

A shorted fault is characterized by a low resistance continuity path to ground (shunted fault). The resistance from the conductor to ground is lower than the surge impedance of the cable for a shorted low resistance fault.

### 3) High Impedance Fault

A high impedance fault contains a resistive path to ground (shunted fault) that is large in comparison to the cable's surge impedance. These type of faults may also demonstrate non-linear resistive characteristics which allow the apparent resistance to vary with the level of applied voltage or current.

## II. LITERATURE REVIEW

- a) In this paper, a technique for identifying the phase with fault appearance in underground cable is presented. The Wavelet transform has been employed to extract high frequency components superimposed on fault signals simulated using Alternative Transients Program (ATP)/Electromagnetic Transients Program (EMTP).  
The coefficients obtained from the Wavelet transform are used in constructing a decision algorithm. Various cases have been investigated so that the algorithm can be implemented. It is found that the proposed method can indicate the fault types with satisfactory accuracy. Abhay Sharma and Akash Mathur, Member, IJAREEIE
- b) In this paper, we come up with their methods for the detection of fault for underground fault detection system but we are not able to know that when actually the fault occurs and also its location. In one of the existing methods, in order to detect the location of the fault, some algorithm has to be implemented and some calculations have to be made which could consume a bit of time and till then there might be a chance that major loss could occur but here it's not so, by the implementation of the proposed method, real time data will be easily known and if any fault occurs then there will be a decrement or increment in the actual value and its fault location will be easily known to the authorities as the real time data can be retrieved from the server in mobile phones or in the laptop. Abhas, Abhinav Shukla, Riwi Koma, Member, IJCTA
- c) This paper explains the importance of locating faults in the distribution network and reviews some of the cable fault locating methods that are mostly used in practical field. There is a need to immediately indicate the occurrence of a fault via remote communication. Therefore we need to implement some techniques which will help power utilities in immediate indication of fault occurrence and accurate methods for locating faults. To facilitate the development, the preliminary investigation requirements and the essential segments to be verified are presented in this paper. Shweta Gajbhiye, S. P. Karmore, Member, IJCSN

## III. EXISTING SYSTEM

In the existing system, the underground cable fault is located using a microcontroller. This system proposes only the detection of short circuit fault. When any fault like short circuit occurs, voltage drop will vary depending on the length of fault in cable, since the current varies.

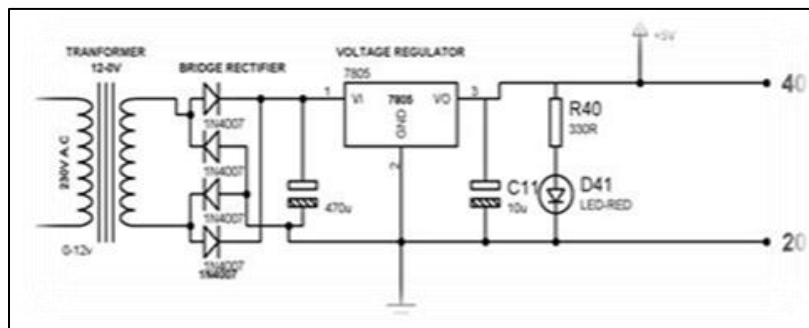

Fig. 1: Launch Pad System

A set of resistors are therefore used to represent the cable and a dc voltage is fed at one end and the fault is observed by detecting the change in voltage using an analog to voltage converter and a microcontroller is used to make necessary calculation so that the fault distance is located in kilometers and displayed using a LCD display.

### A. Drawbacks

The existing system provides only the detection of short circuit fault in the underground cable. Usage of 10bit ADC reduces the accuracy in locating the fault and precise values are not obtained. The location of fault in cable is employed only for a particular distance. Moreover, the system supports to cables ranging from 1kv to 500kv. It does not employ the other cable fault detection. It may increase the investment cost due to the application of various components.

## IV. FAULT LOCATION METHODS

The faults occurring in the power lines and cables can be classified into four main categories- short circuit to another conductor in the cable, short circuit to earth, high resistance to earth and open circuit. Not all approaches work best for each type of fault. Four methods that are mostly used in detecting fault location are described as follows.

- A frame
- Thumper
- Time Domain Reflectometer (TDR)
- Bridge methods

**A. A-Frame Method**

In A-Frame method, a pulsed direct current (DC) is injected into the faulty cable and earth terminal to locate the ground fault. The DC pulse will flow through the conductor and return via earth from the earth fault location back to the ground stake as shown in Figure 2. The flow of pulsed DC through the ground will produce a small DC voltage. A sensitive voltmeter is used to measure the magnitude and direction of the DC voltage in segments of the earth along the cable route. Analyzing the results of the measuring voltage along the route, the location of the fault in the cable can be pinpointed AFrame is an accurate method but it is not the fastest one, since the operator has to walk along the length of the cable from the transmitter to the ground fault.

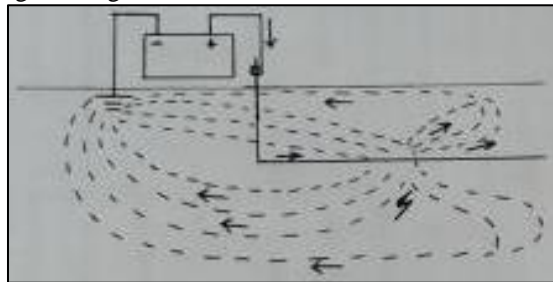

Fig. 2: A-Frame Method of Finding Cable Fault Location

**B. Thumper Method**

Thumper is basically a high voltage surge generator which is used to apply a reasonable high voltage to the faulty core of an underground cable to generate a high current arc resulting in a loud noise to hear above the ground. This method requires very high current thump at voltages as high as 25 kV to make underground noise loud enough to be heard from the ground. In thumper method of finding fault locations Like A Frame, the thumper method requires an operator needs to walk along the path of the cable and listen for the sound from above the ground. Different ground conditions, nearby traffic and noises may make this sound hard to listen to make a clear distinction.

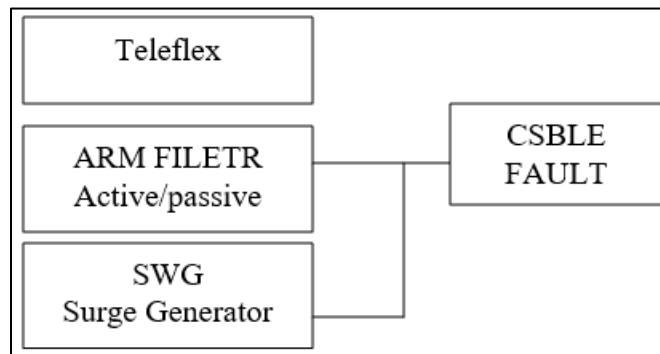

Fig. 3: A Thumper Method of Fault Finding

**C. Time Domain Reflectometry (TDR)**

In the Time Domain reflectometry (TDR) method, a low energy signal is sent through the cable where the perfect cable with the uniform characteristic impedance returns the signal within a known time and with a known profile. This time and profile of the signal is altered once the cable has impedance variation due to any fault. The impedance variation causes a portion of the signal reflected back to source. The reflected signal fortifies the original signal when there is an increase in characteristic impedance at the fault location, while it opposes the original signal when there is a decrease in characteristic impedance. Graphical representation on the Time Domain Reflectometry (TDR) screen gives the user the distance to the fault in time units. The actual distance can be calculated by multiplying the time by signal velocity. The functional block diagram of a TDR is given in Figure 4.

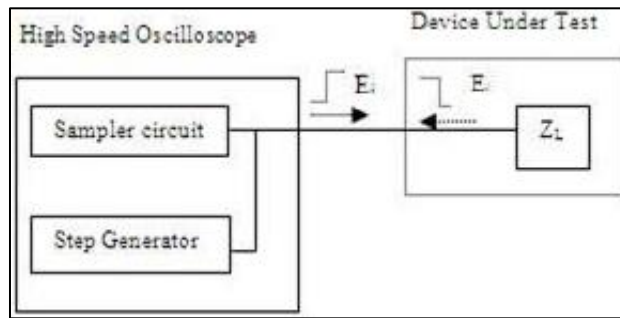

Fig. 4: Functional Block Diagram of a TDR

#### D. Bridge Method

Bridge methods used for locating faults in underground cables are based on modified Wheatstone circuit where direct current is used to measure the resistance in order to calculate distance of the fault in percentage of the total line length. Murray and Glaser bridges use the similar principal for calculating the distance of the fault.

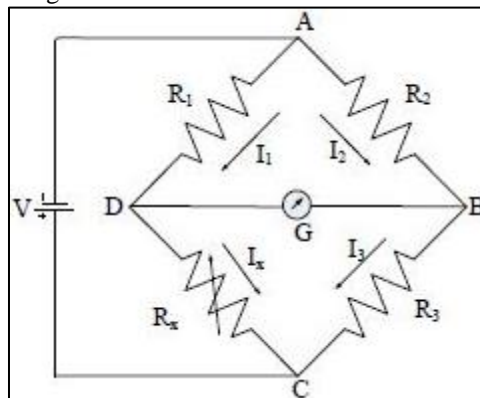

Fig. 5: Bridge Circuit

### V. PROPOSED SYSTEM

The proposed system also follows the same principle of Ohm's law. Here the detection of short circuit and open circuit fault, resistive variation and with the advancement of technology the temperature indication of the underground cable can be monitored. The various components used in the system are basically a current sensor, arduino Uno, Wi-Fi modem, LCD. Measuring the amount of current is one of the important task and earlier it was achieved by placing a resistor in the current paths but due to that the heat dissipation was more so now various technologies came up which measures current without any heat loss, one of such current sensor is MEMs silicon based Piezoelectric AC current sensor, which operates at resonant frequency and gives an improved response when placed near to current carrying conductor. Here, we have used Arduino, due to its miniature size, it can be placed over breadboard and reads the sensed values and as per the coding done by the user it performs specific tasks. In this, microcontroller (Arduino) will receive the input from the sensor and according to it, the controller circuit will perform some set operations like displaying of data in LCD display which is interfaced with it or serially communicating the real time data through Tx-pin of microcontroller.

#### A. Advantages

This method provides précised accuracy in determining the location of cable fault. Consumes low power in terms of nano watts, 80 MHz and dmips speed. Accuracy is improvised using the 12bit ADC. Compact size, small package of 64 pin lqfp. Serial on-board programming. No external programming voltage needed.

### VI. WORKING

Various components used in the system are basically a current sensor, arduino Uno, Wi-Fi modem, LCD display and there interfacing diagram is also shown in figure 6. Measuring the amount of current is one of the important task and earlier it was achieved by placing a resistor in the current paths but due to that the heat dissipation was more so now various technologies came up which measures current without any heat loss, one of such current sensor is MEMs silicon based Piezoelectric AC current sensor, which operates at resonant frequency and gives an improved response when placed near to current carrying conductor. Here we have used Arduino, due its miniature size it can be placed over breadboard and reads the sensed values and as per the coding done by the user it performs the specific tasks. Like in this, microcontroller (Arduino) will receive the input from the sensor

and according to it, the controller circuit will perform some set operations like displaying of data in LCD display which is interfaced with it or serially communicating the real time data through Tx-pin of microcontroller. Wi-Fi module acts as a medium which connects any of the physically assembled system with internet and transmits the data in the server.

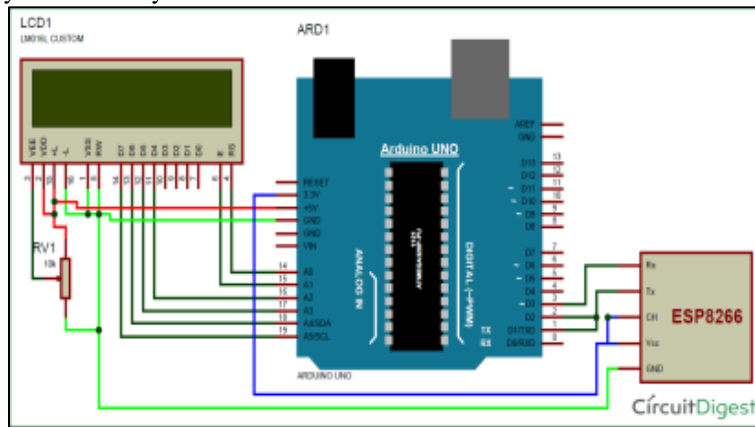

Fig. 6: Interfacing Diagram of Arduino & Wi-Fi Module

Wi-Fi modem is usually interfaced with Arduino is ESP8266. It's cheap and an easy way to interface with any microcontroller platform wirelessly through internet. Now coming to its pin configurations, it consists of 8 pins but the pins which are actually used are Tx pin, Rx pin, CH\_PD pin, Vcc, Gnd. CH\_PD is the enable pin which is active high pin and by giving input HIGH it enables Wi-Fi and connects the system with internet and any of the sensed values can be serially transmitted to the server. For example, an ARM based power meter works on similar principle. An interfacing diagram of Arduino with Wi-Fi module is shown in the proteus simulation software in figure 6. And the same is seen in assembling both the components whose circuit diagram is shown in figure 7, where we are placing some resistors in order to avoid the burning effect of overall circuitry. LCD display used here is 20 X 4 which is a flat panel display which uses a group of LEDs and writes the sensed value in its display screen and in the circuitry itself there is a facility through which we can control the LCD brightness and intensity. Now, figure shown below is the block diagram of the system where current sensors are placed across the underground cable and the sensor is interfaced with arduino and further arduino is interfaced with 20 x 4 LCD display and Wi-Fi modem. Sensed values from the current sensors goes to microcontroller and from there the values gets displayed in the LCD display and further serially communicated towards server and from server the real time data can be retrieved in smart phones or laptops through IoT. For example, for an underground cable the correct value is 5 amperes, then the value is sensed by the sensor and the similar value is shown in the display and transmitted in the server and supposes any fault occurs then the faulty value assures that the fault has been detected and then the further more actions can be taken.

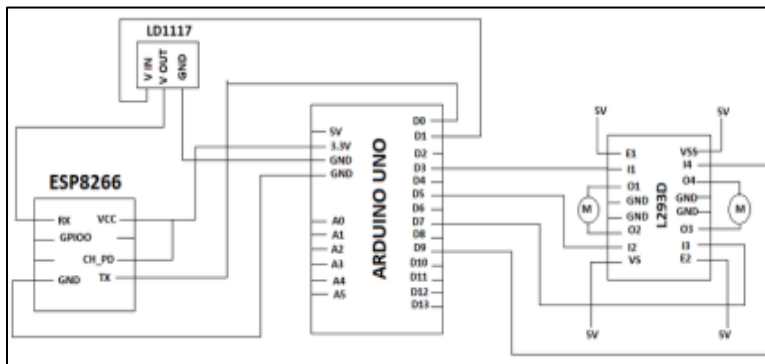

Fig. 7: Circuit Diagram of Arduino & Wi-fi Module

The system is simulated in proteus simulation software in order to check its accuracy and it's shown in the figure 7. The circuit diagram shows the interconnection of the components in which the current sensor output pin is connected to the analog input pin of arduino which is A0, and a DC rectified power supply is given to the arduino. After that 20 X 4 LCD display is interfaced with arduino, where we have connected pin number 4, 5 of LCD display to 13, 12 pins of Arduino which are PB5/ SCK and PB4/MISO respectively and we kept the R/W pin of display at ground which will write in the LCD display and the data pins of lcd display (D4, D5, D6, D7) are connected to 7, 6, 5, 4 pins of arduino which are PD7/AIN1, ~PD6/AIN0, ~PD5/T1, PD4/T0/XCK respectively. After that we interfaced Wi-Fi module (ESP8266) with arduino in which we connected pin 1, 2 of arduino to the Tx pin of Wi-Fi module and then pin 3 of arduino is connected to Rx pin of Wi-Fi module and we gave power of 3.3 V to Vcc and CH\_PD pin of Wi-Fi module which is an active HIGH pin, by giving logic "1" enables Wi-Fi module and connects the assembled system with internet and provided with ground in GND pin of Wi-Fi module.

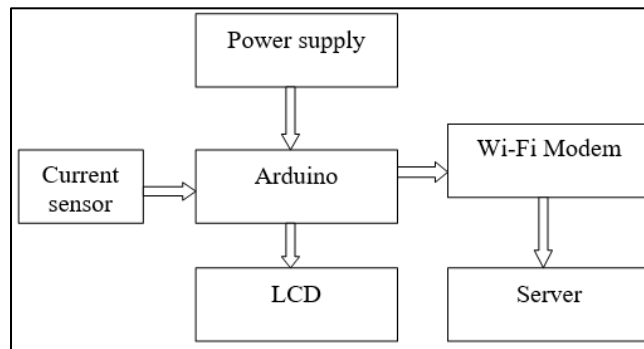

Fig. 8: Block Diagram of IoT based Underground Cable Fault Detection & Monitoring System

## VII.RESULT

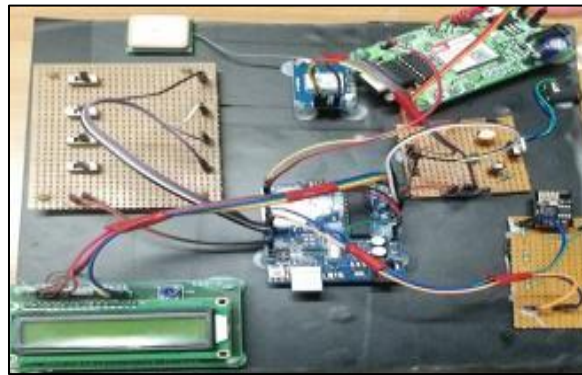

Fig. 9: Prototype of Project

The prototype of project is shown in the figure 9 which consists of an Arduino kit, 16x2 LCD, switches, Wi-Fi modem and a GSM module which are all activated by a power supply integrated on a single board.



Fig. 10: No Cable Fault Found

Whenever the underground cables are said to be working fine and no problem persists, the message “NO FAULT IN UNDERGROUND CABLE” gets displayed as in figure 10.



Fig. 11: Cable Fault at 3km

When a fault is said to be occurring in the underground cable, the message “CABLE FAULT IN \_\_ KM” gets displayed as in figure 11

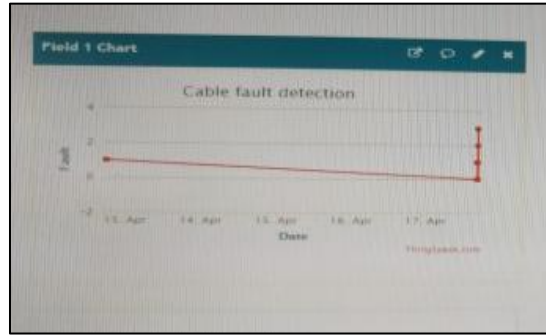

Fig. 12: Data Stored through IoT

The real-time status of the underground cable can be known to the controller by accessing data through IoT as shown in the figure 12.

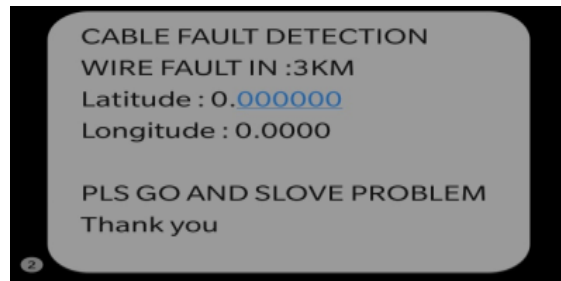

Fig. 13: Latitude & Longitude Value

By the help of the GSM module used in the circuit, the accurate data of the cable fault can be obtained by the help of longitude and latitude values in real-time as shown in the figure 13.

## VIII. CONCLUSION

Though researchers came up with these methods for the detection of fault for underground fault detection system but somewhere we were not able to know that when actually the fault had occurred, its location and also in one of the existing methods in order to get the location of the fault certain algorithm has to be performed and some calculations which could be a bit time consuming and till then there might be a chance that major loss could occur but here it's not so, by the implementation of the proposed method, real time data will be easily known and if any faulty case occurs then there will be decrement or increment in the actual value and its fault, location will be easily known to the authorities as the real time data can be retrieved from the server in mobile phones or by laptop. Not only this, life of the cable will also get increased because the supply transmission of the power can be stopped till the fault gets repaired and through this the unnecessary losses which are developed though the leakage of current can be avoided.

## REFERENCES

- [1] Abhas, AbhinavShukla, RiwiKomal, Rajesh Singh, Anita Gehlot, “Underground Cable Fault Detection and Monitoring System” IJCTA, 9(22), 2016, pp. 145-150
- [2] ShwetaGajbhiye, S. P. Karmore, “Cable Fault Monitoring and Indication”IJCSN, Volume 2, Issue 4, August 2013
- [3] Priyanka.R and B.Priya, BE Student, VelTech Engineering College Avadi, Chennai TamilNadu, India, “Underground Cable Fault Detection” Volume 3(3), ISSN: 2394-9333
- [4] Abhay Sharma, AkashMathur, Rajat Gupta, R.B.S. Engineering Technical Campus, Bichpuri, Agra, India, “Underground Cable Fault Distance Locator”, IJAREEIE, Vol. 6, Issue 4, April 2017
- [5] Faizan Mohammad Yakub, Dinesh Rojatar, Govt.College of Engg. Chandrapur, Maharashtra, India, “Arduino Cable Fault Detector “A Survey”, January 2017, Volume 4, Issue 01 JETIR (ISSN-2349-5162)
- [6] AkashJagtap, JayeshPatil, BhushanPatil, GF’s G.C.O.E Jalgaon, Maharashtra, India, “Arduino based Underground Cable Fault Detection”, ISSN : 2454-9150 Vol-03, Issue 04, May 2017
- [7] PreetiJaidka, ShreeyaSrivastava, JSS Academy of Technical Education, Noida, “Underground Cable Fault Detector Using Arduino” IJEECS ISSN 2348-117X Volume 5, Issue 5 May 2016
- [8] T.Nandhini, J.Shalini, T. SaiSangeetha, Dr. Mahalingam College of Engineering and Technology, NPT - MCET Campus, Tamil Nadu, India, “Underground Cable Fault Detection using Arduino”, IJESC, Volume 7 Issue No.4, 2017
- [9] T. S. Sidhu and Z. Xu, —Detection of incipient faults in distribution underground cables, IEEE Trans. Power Del., vol. 25, no. 3, pp. 1363–1371, Jul. 2010.
- [10] T. S. Sidhu and Z. Xu, —Detection of incipient faults in distribution underground cables, IEEE Trans. Power Del., vol. 25, no. 3, pp. 1363–1371, Jul. 2010.