

Credential Access Control and Weight Management for Elevator

Khairnar Saloni Surendra
*Department of Electronics & Telecommunication
Engineering
University of Pune Maharashtra, India*

Gangurde Tejal Chandrakant
*Department of Electronics & Telecommunication
Engineering
University of Pune Maharashtra, India*

Kasar Devyani Vinod
*Department of Electronics & Telecommunication Engineering
University of Pune Maharashtra, India*

Abstract

It is very essential means of the transportation in the modern buildings, Elevator becomes increasingly demanding in terms of safety, reliability, comfort, efficiency and energy saving. How to use the control method and the composition of the structure to be able to elevator to provide better service and to better meet people's needs has always been the field of elevator control research. The aim of the project is to design and implement an elevator control using Arduino. The device controls the lift motion by means of accepting the floor level as input and generate control signal as output. The lift controller system is based on the concept of finite state machine technology. According to the FSM technology the elevator process can be define with the help of different states. In the FSM technology there is a change from one state to another state likewise in the elevator there will be the change from one floor to the floor. In this propose system we are using fingerprint module for the person identification. The elevator system is operated by the main controller by a set of program instruction the information of the every elevator system is sends to the main controller. In that teachers, students or staff can be accessed different lift. Hence, the teacher important time is not loss. Also if teacher lift is busy then for that time they can use student lift also for their priority.

Keywords: elevator, lift control system, modelling, control system, FSM, Interactive system

I. INTRODUCTION

An elevator is a simple machine that is used to save human efforts and time. The elevator won't need to use much energy at all the time because it will always be getting back as much (when it goes down) as it gives out (when it goes up). It uses more energy to lift people up but it would have no way of getting that energy back [1]. So elevator is the good example of law of energy conservation. When people are coming down there is small amount of loss in cable and brakes.

Elevator controller is developed for the N number of floors. The controller consist control buttons to move the elevator in upward and downward direction.[1] The floors of the building consists call buttons to call the elevator at the floors and also use the finger print to call the elevator.

The elevator system is operated by the main controller by a set of program functions. The function of the every elevator system is sends to the main controller. In that teacher, student or staff can be access different lift. Hence the teacher important time is not loss. Also if teacher list is busy then for that time they can use student lift also for their priority.

The project involves a system including the LCD outside the elevator the person entering in the elevator then the motion is depend on the weight of the object. This system is operated by human beings. These paper introduces basic structure, control principle and realization method of the elevator control system in detail.

II. OPERATIONAL SEQUENCE

The Fig. 1 and Fig. 2 shows the elevator structure developed with I1, I2 and I3 are ground floor, 1st floor and 2nd floor call switches; I8 is an emergency switch; I4, I5 and I6 are limit switches used to detect current lift position. [3] The sequence operation for elevator system is shown in flowchart of Fig. 3 and is describe as follow:

- When the staff, students was enters in the elevator, light and fan switched ON automatically.
- Desired floors selected by person.
- Then the door is automatically closed, motor is switched ON and brakes is released.
- The direction of rotation of motor of the elevator depends upon floor selection; current elevator position and when the directions are different then the floor selected first will get the higher priority.
- When the selected floor is reached at the destination then the limit switch of selected floor gets activated and switch OFF the motor.

- Brakes get activated.
- Selected floor is reached at the destination, then passenger out of lift and door is automatically closed.
- When none of the floor calling switches are pressed up to the 40 seconds time duration, then elevator fan and light will automatically be switched OFF to save the electricity.
- The whole elevator system is stop by emergency stop button in case of any emergency or for the maintenance purpose. During this process the elevator's fan and lights will be ON.
- If there is a power is lacking during elevator transition, PLC will remember the sequence of last status of elevator. When power is restored elevator then it will be automatically operated by their past status.

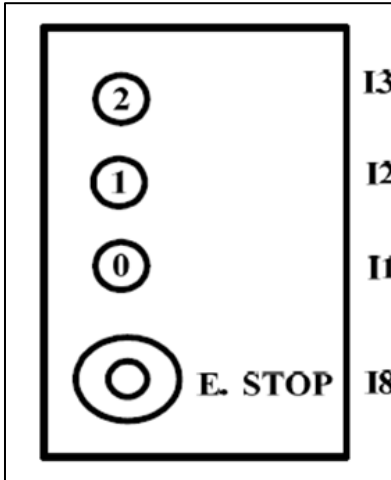

Fig. 1: Floor calls with emergency stop button.

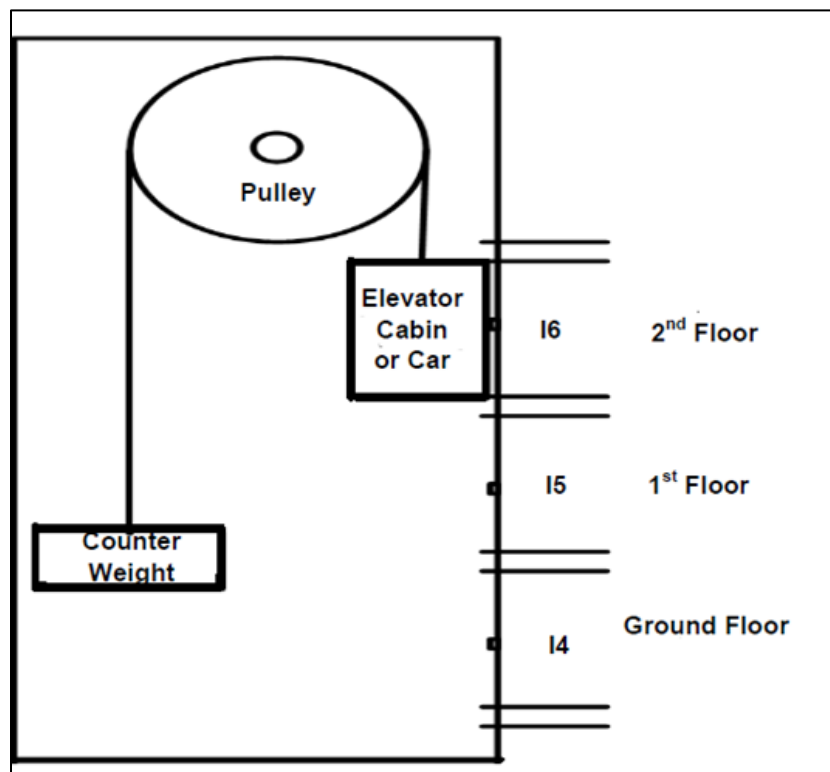

Fig. 2: Elevator Structure

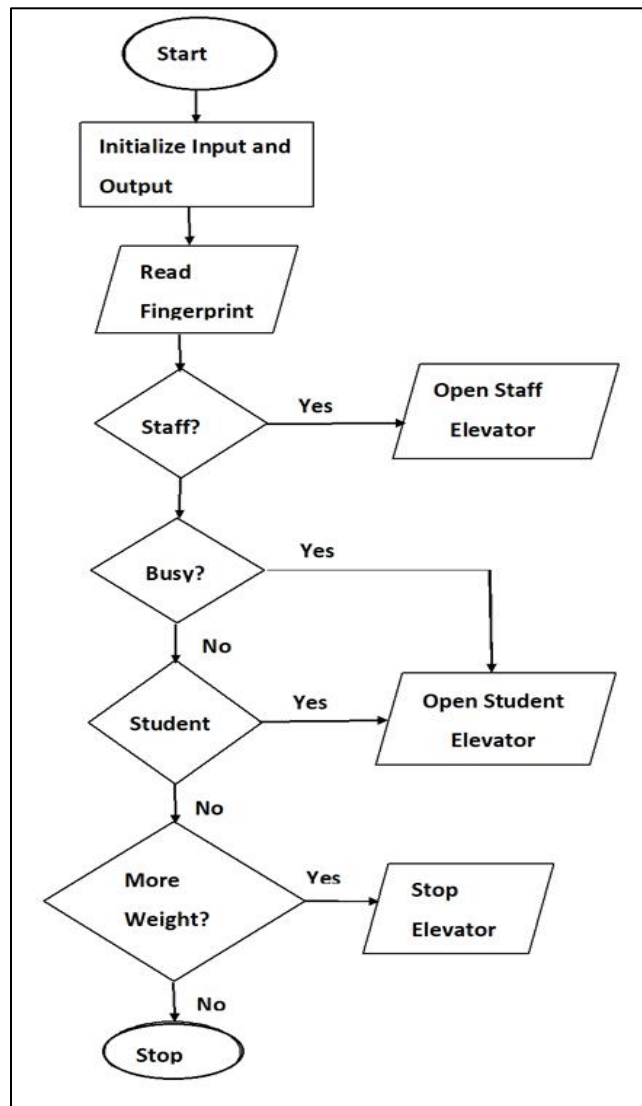

Fig. 3: Flowchart for Elevator System

III. CONTROL SYSTEM OVERALL DESIGN

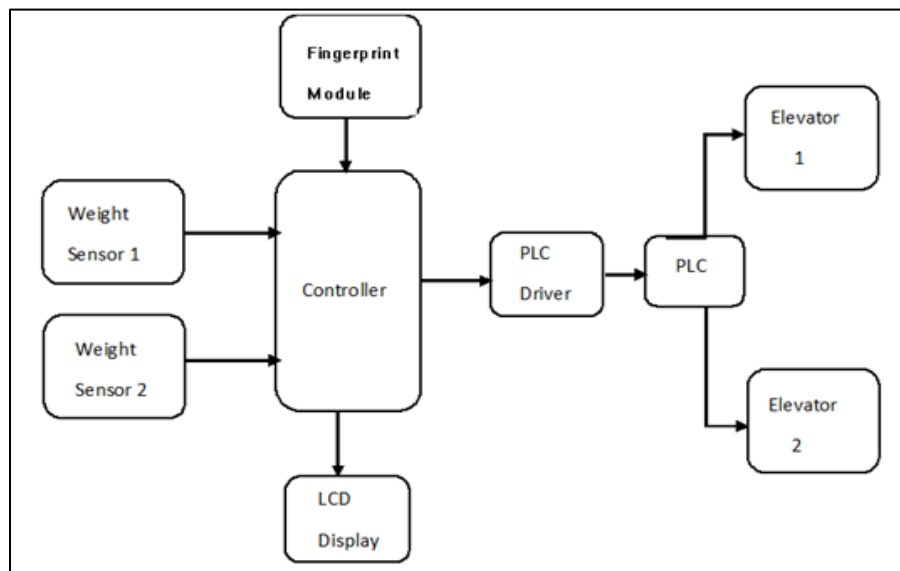

Fig. 4: Block diagram of credential access control and weight management for Elevator

A. Controller

ARDUINO Pro Mini (Fig 4) development board is used as a PI controller. PI controller is implemented using the PID library. The process has only single superior pole so it can be controlled quite well with a PI controller. [9] PI controller parameters are obtained with experimental method, and uses difference between reference value which is set by another microcontroller and feedback value as an input. First the proportional gain is increased to get a little overshoot and then the integral constant is decreased from large value too small to obtain the response with given overshoot [9]. Output is a PWM signal with modifiable duty-cycle.

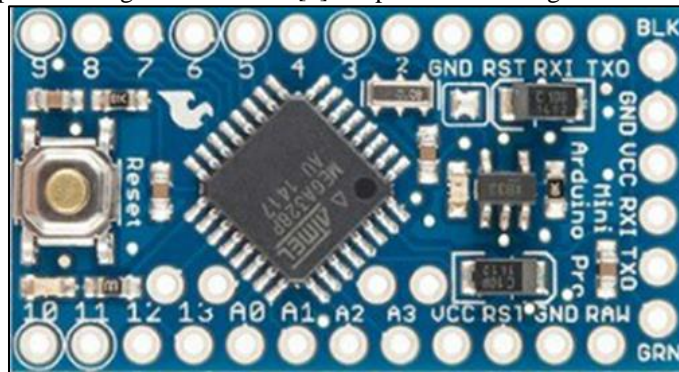
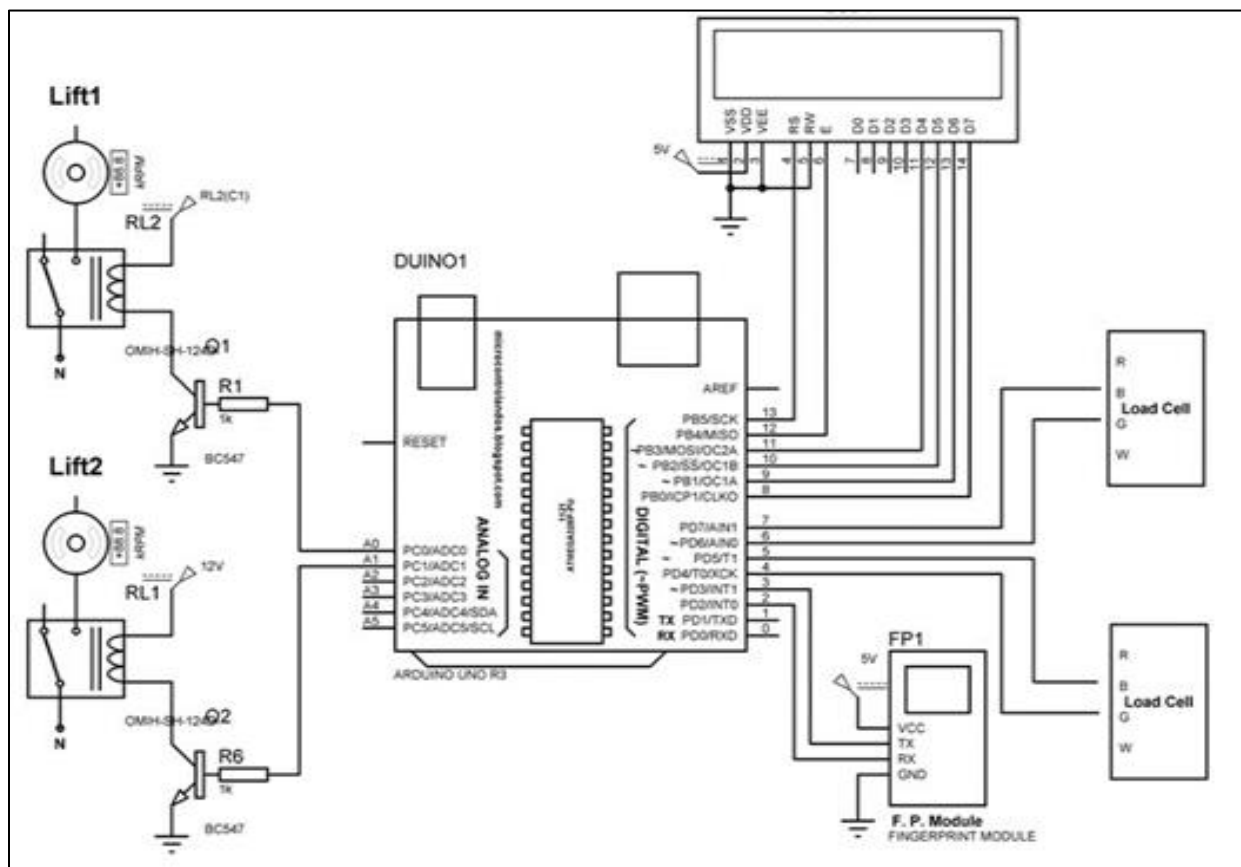

Fig. 5: Overview of an ARDUINO Pro Mini board

B. Fingerprint Module

Fingerprint module helps to identify of a person, using two processes, namely first one is finger enrolment and other finger matching. Data security is one of the higher role for the growth of the fingerprint module market, globally. Fingerprint sensor system, like the one in the following figure, made fingerprint recognition more accessible and it is very easy to add in the projects. This means that is super easy to make fingerprint collection, registration, comparison and search. These modules with the FLASH memory to store the fingerprints and work with the any microcontroller or the system with TTL serial.

IV. HARDWARE CONTROL OF ELEVATOR CONTROL SYSTEM



V. CONCLUSIONS

The elevator model is made with the aim of acquiring the knowledge of automation and regulation. It is useful for laboratory exercises because the parameters of regulator are easy to change. If the parameters are changed, then the speed of cabin will be different.

Benefits in using such system are:

- ARDUINO platform is very easy to program and is corresponding with the many operating systems.
- It is easy to change elements, components and their parameters in the entire code.
- It is feasible to measure all signals between microcontrollers and other elements or components. However, there are certain disadvantages. They include:
 - low operating voltage and possible disturbances,
 - ARDUINO Mini Pro and ARDUINO Mega have not enough interrupt pins, so microcontroller needs to have additional algorithm to constantly check changes of states on digital inputs.

ACKNOWLEDGEMENT

The authors are thankful to the Technology Information Forecasting and Assessment Council and for providing the necessary facilities to perform the research work.

REFERENCE

- [1] J.R. Fernandez, and P. Cortes, "A survey of Elevator Group Control Systems for the vertical transportation: A look at recent literature," *IEEE Control Systems*, vol. 35, no. 4, pp. 38-55, 2015
- [2] S. Lupin, Kyaw Kyaw Lin, A. Davydova, and Y. Vagapov, "The impact of the sensors' implementation on Elevator control system", in *Proc. IEEE East-West Design and Test Symposium*, Kiev, 2014, pp. 217-219.
- [3] N. Toygar, "Vertically Motion on the Horizontally Direction," *Elevator World Magazine*, vol. 73, 2004
- [4] A. Jozic. T. Špoljarić, D. Gadže, "Laboratory Model of an Elevator System: Control with the Three Speed Profiles", 39th International Convention, MIPRO, Opatija, 2016.
- [5] National Elevator Industry, "Elevator and escalator fun fact," National Elevator Industry, Inc., 2017.
- [6] M. A. Ulla and M. Saeed, "Design and implementation of the elevator control system using fpga," *International Journal of Innovation and Applied Studies*, vol. 9, no. 4, pp. 1541–1546, 2014.
- [7] "Deumo tachometer," <https://www.wurtec.com/en/product/test-measuring-equipment-meters/tachometerwheel-12-circ12-240-A1>, Wurtec Inc., 2015, accessed 2017-07-19.
- [8] J. Sorsa, H. Ehtamo, J.-M. Kuusinen, M. Ruokokoski, and M.-L. Siikonen, "Modelling uncertain passenger arrivals in the elevator dispatching problem with destination control," *Optimization Letters*, pp. 1–15, 2017.
- [9] "ARDUINO Tutorials", www.arduino.cc, 2016.
- [10] Zhouhua. Design and Realization of the Elevator PLC Control System [D]. Xian: University of Electronic Science and Technology, 2012.